

# Screen 5B

Three-way bi-amp system

## features

- ▶ Three-way design
- ▶ Bi-amped operation
- ▶ Very low distortion mid-range
- ▶ Full pattern control to 300Hz
- ▶ 90° x 50° dispersion

## applications

- ▶ Behind screen placement
- ▶ Large scale cinemas



cinema

The Screen 5B full-range system has been developed for use in medium to large-scale cinema environments. The system consists of a 2 x 15" (380mm) low frequency section plus a unique mid-range and high frequency horn which exhibits ideal pattern control across its operating range from 300Hz-20kHz.

The Screen 5B benefits from the same compound mid-range/HF horn as the Screen 6 giving exemplary performance and focused coverage over its entire operating bandwidth.

The Screen 5B would normally be operated as a bi-amped system using the Martin Audio CMX2A Cinema Controller.

Century Point, Halifax Road, Cressex Business Park,  
High Wycombe, Buckinghamshire HP12 3SL, England.  
Telephone: +44 (0)1494 535312 Facsimile: +44 (0)1494 438669  
E-mail: [info@martin-audio.com](mailto:info@martin-audio.com)  
All information is Copyright © 2003 Martin Audio Ltd.



# Screen 5B

Three-way bi-amp system

overall dimensions

cinema

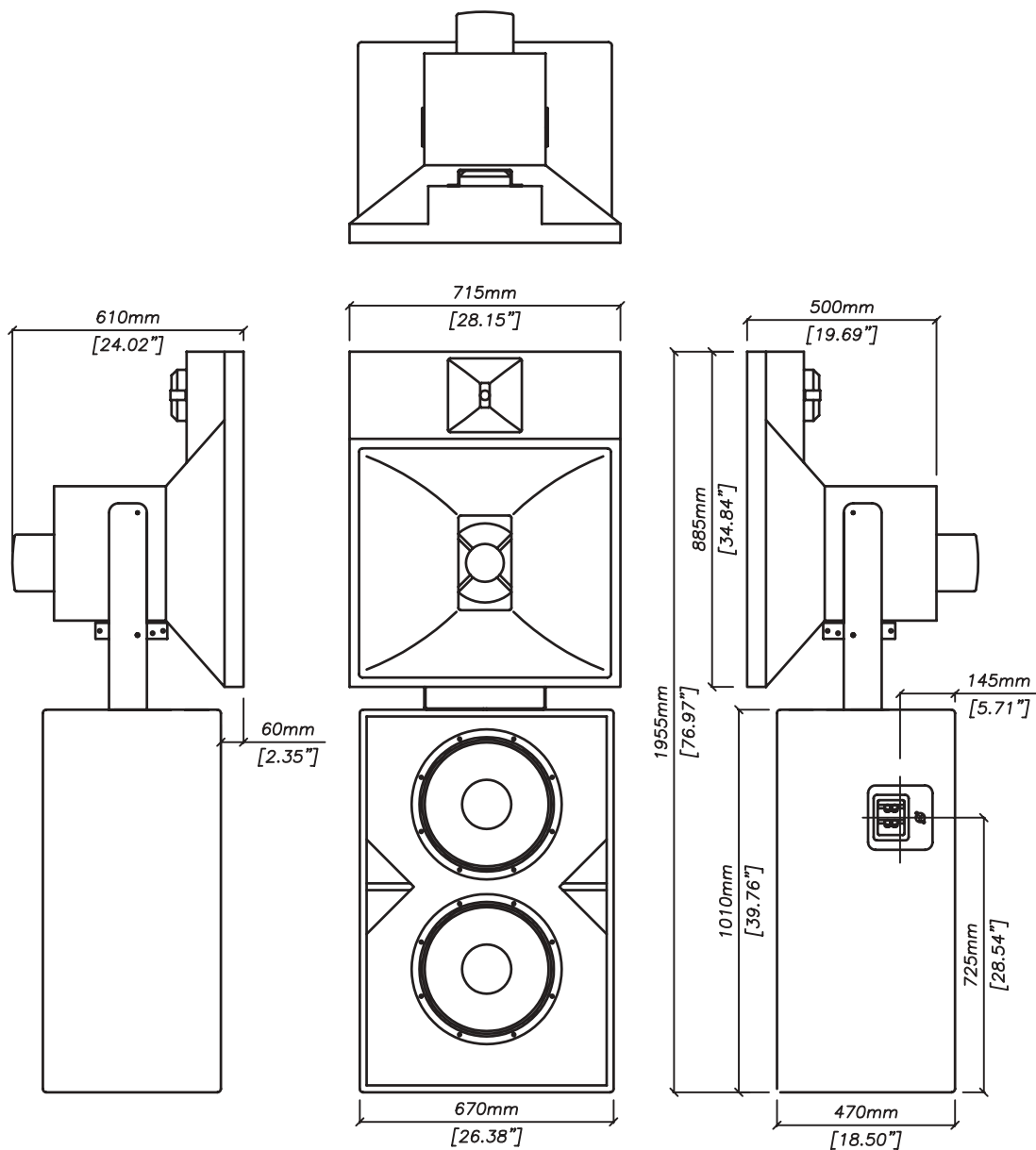

SCREEN 5B

Century Point, Halifax Road, Cressex Business Park,  
High Wycombe, Buckinghamshire HP12 3SL, England.  
Telephone: +44 (0)1494 535312 Facsimile: +44 (0)1494 438669  
E-mail: [info@martin-audio.com](mailto:info@martin-audio.com)  
All information is Copyright © 2003 Martin Audio Ltd.



# Screen 5B

Three-way bi-amp system

## technical specifications

TYPE	Three-way bi-amp screen system
FREQUENCY RESPONSE (1)	45Hz-20kHz $\pm$ 3dB
DRIVERS	2 x 15" (380mm) bass driver 6.5" (165mm) mid driver 1" (25mm) exit compression driver
RATED POWER (2)	LF: 800W AES, 3200W peak MF + HF: 150W AES, 600W peak
SENSITIVITY (3)	LF: 100dB MF + HF: 107dB
NOMINAL IMPEDANCE	LF: 4 ohms MF + HF: 8 ohms
DISPERSION (-6dB)	90° horizontal, 50° vertical
CROSSOVER	300-500Hz active, 2.2kHz passive
ENCLOSURE	Vented
FINISH	Matt black
CONNECTORS	Binding Posts
DIMENSIONS	LF: (W) 670mm x (H) 1010mm x (D) 470mm (W) 26.4ins x (H) 39.8ins x (D) 18.5ins MF/HF: (W) 715mm x (H) 885mm x (D) 610mm (W) 28.1ins x (H) 34.8ins x (D) 24ins
WEIGHT	LF: 61kg (134.5lbs) MF/HF: 18kg (39.6lbs)

### Notes

- (1) Measured on-axis in half space at 2 metres, then referred to 1 metre.
- (2) AES Standard ANSI S4.26-1984.
- (3) Measured in half space conditions at 2 metres with 1 watt input, using band limited pink noise, then referred to 1 metre.
- (4) Measured in half space conditions at 2 metres using band limited pink noise, then referred to 1 metre.

### Trade Descriptions Act

Due to Martin Audio's policy of continuing improvement, we reserve the right to alter these specifications without prior notice. Martin Audio is committed to refining state of the art sound reinforcement, combining in-depth product and field applications research with advanced manufacturing techniques. Every Martin Audio product is built to the highest manufacturing standards and rigorously tested to ensure that it meets the performance criteria specified in the design.

## architectural and engineering specifications

The loudspeaker system shall be of the three-way bi-amp type supplied in two separate sections. The bass section shall consist of two 15" (380mm) direct radiating reflex loaded low frequency transducers in a shallow profile enclosure. The large format compound horn section shall consist of one 6.5" (165mm) treated cone driver mounted on a 90° x 50° horn with a 'phase-ball' loading device and one 1" (25mm) exit HF compression driver mounted on a 90° x 50° constant directivity horn. The loudspeaker system shall be operated with a separate electronic controller providing a 300-500Hz crossover between low and mid/high frequency sections. The mid and high frequency sections shall be integrated by an internal 2.2kHz passive crossover network.

Performance of the loudspeaker system with its electronic controller shall meet or exceed the following criteria:

Frequency response measured 1 metre on axis shall be 45Hz-20kHz  $\pm$  3dB.

High frequency dispersion at -6dB points shall be 90° H x 50° V.

Power handling shall be 800W AES, 3200W peak LF, 150W AES, 600W peak MF + HF.

Rated impedance shall be 4 ohms LF, 8 ohms MF + HF. Sensitivity 1 Watt/1 metre shall be 100dB LF, 107dB MF + HF.

Dimensions LF: (W) 670mm x (H) 1010mm x (D) 470mm (26.4ins x 39.8ins x 18.5ins) MF/HF: (W) 715mm x (H) 885mm x (D) 610mm (28.1ins x 34.8ins x 24ins).

Weight LF: 61kg (134.5lbs) MF/HF: 18kg (39.6lbs).

The loudspeaker system shall be the Martin Audio Screen 5B.

Century Point, Halifax Road, Cressex Business Park,  
High Wycombe, Buckinghamshire HP12 3SL, England.  
Telephone: +44 (0)1494 535312 Facsimile: +44 (0)1494 438669  
E-mail: [info@martin-audio.com](mailto:info@martin-audio.com)  
All information is Copyright © 2003 Martin Audio Ltd.

