

# Blackline H2

Two-way active/passive mid-high

## features

- ▶ Two-way active/passive mid-high
- ▶ Hybrid™ mid-range horn
- ▶ 'Phase-ball' loaded mid-driver
- ▶ Extended mid-range performance down to 150Hz
- ▶ M8 inserts for cabinet rigging
- ▶ Five year limited warranty

## applications

- ▶ Mid/high for larger club performance
- ▶ Large scale club installs



portable club

The Blackline H2 is an all-horn, very high performance mid-high pack for dance club and live music stages. It features an innovative Hybrid™ 10" (250mm) mid-range horn with a unique 'phase-ball' loading device. This maintains the 70° x 40° directivity pattern of the mid horn up to 2kHz where a 1" (25mm) exit HF compression driver takes over.

The H2 is housed in a trapezoidal birch ply cabinet and may be horizontally arrayed for wide coverage applications. Its twelve M8 inserts make a variety of mounting methods possible including horizontal or vertical mounting.

The H2 has a switchable active/passive 2kHz crossover network to permit either passive or bi-amp operation. The mid section extends down to 150Hz where it can be crossed over into an S218 subwoofer. A Martin Audio M3 Electronic Controller is available to provide H2/S218 crossover and limiter facilities. See the M3 Electronic Controller Technical Specifications for suitable M3 Controller Cards.

Century Point, Halifax Road, Cressex Business Park,  
High Wycombe, Buckinghamshire HP12 3SL, England.  
Telephone: +44 (0)1494 535312 Facsimile: +44 (0)1494 438669  
E-mail: [info@martin-audio.com](mailto:info@martin-audio.com)  
All information is Copyright © 2003 Martin Audio Ltd.



# Blackline H2

Two-way active/passive mid-high

polar plots

portable club

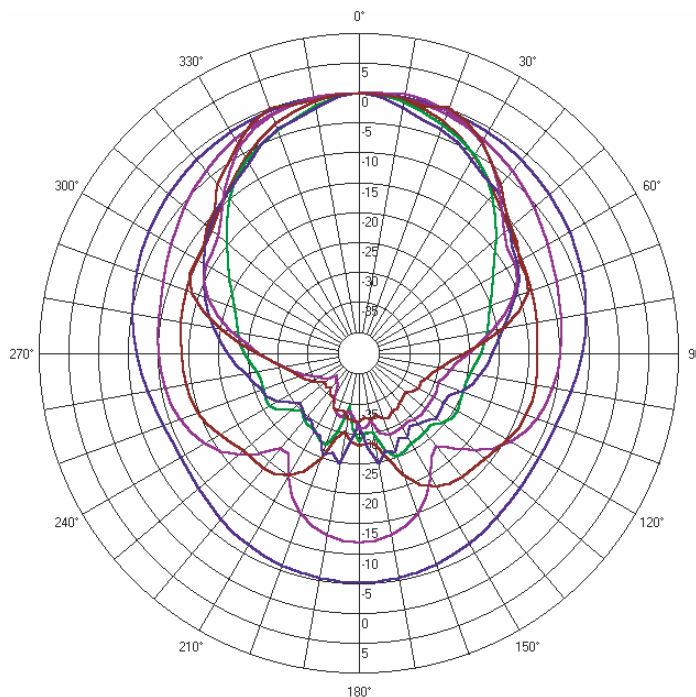
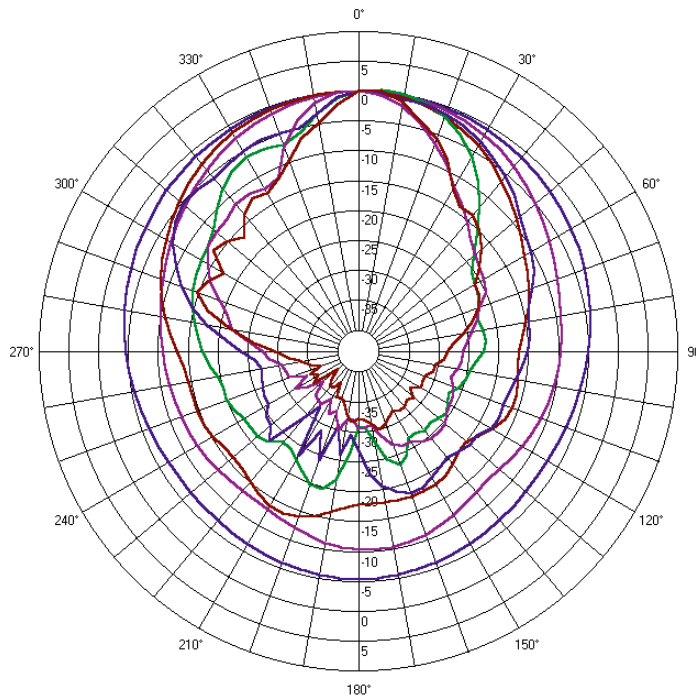

Century Point, Halifax Road, Cressex Business Park,  
High Wycombe, Buckinghamshire HP12 3SL, England.  
Telephone: +44 (0)1494 535312 Facsimile: +44 (0)1494 438669  
E-mail: [info@martin-audio.com](mailto:info@martin-audio.com)  
All information is Copyright © 2003 Martin Audio Ltd.



# Blackline H2

Two-way active/passive mid-high

frequency responses

portable club

H2 Horizontal Magnitude in dB SPL/2.83V at 1 meter

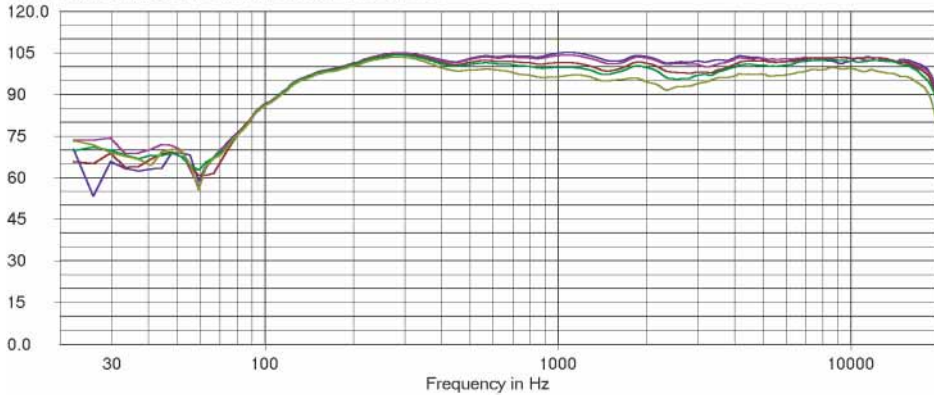

— 0° & 1/3 oct. smoothing — 10° & 1/3 oct. smoothing — 20° & 1/3 oct. smoothing — 25° & 1/3 oct. smoothing  
— 35° & 1/3 oct. smoothing

H2 Horizontal Beamwidth

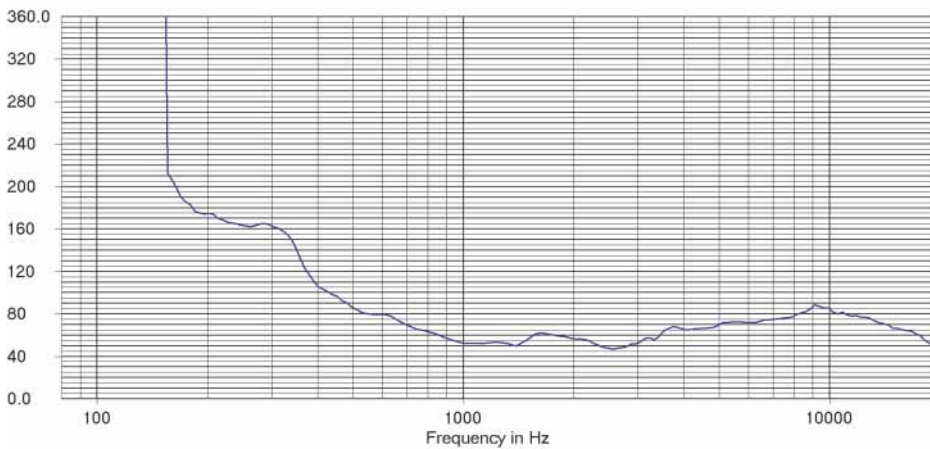

H2 Vertical Beamwidth

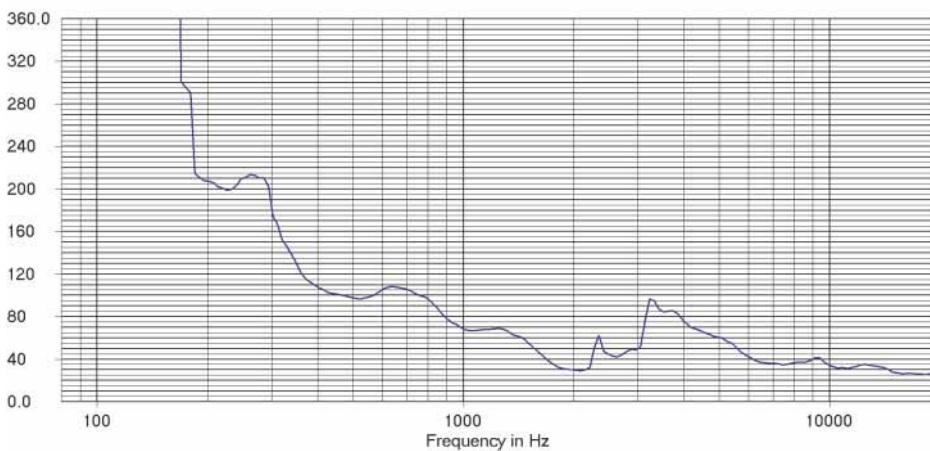

Century Point, Halifax Road, Cressex Business Park,  
High Wycombe, Buckinghamshire HP12 3SL, England.  
Telephone: +44 (0)1494 535312 Facsimile: +44 (0)1494 438669  
E-mail: [info@martin-audio.com](mailto:info@martin-audio.com)  
All information is Copyright © 2003 Martin Audio Ltd.



# Blackline H2

Two-way active/passive mid-high

overall dimensions

portable club

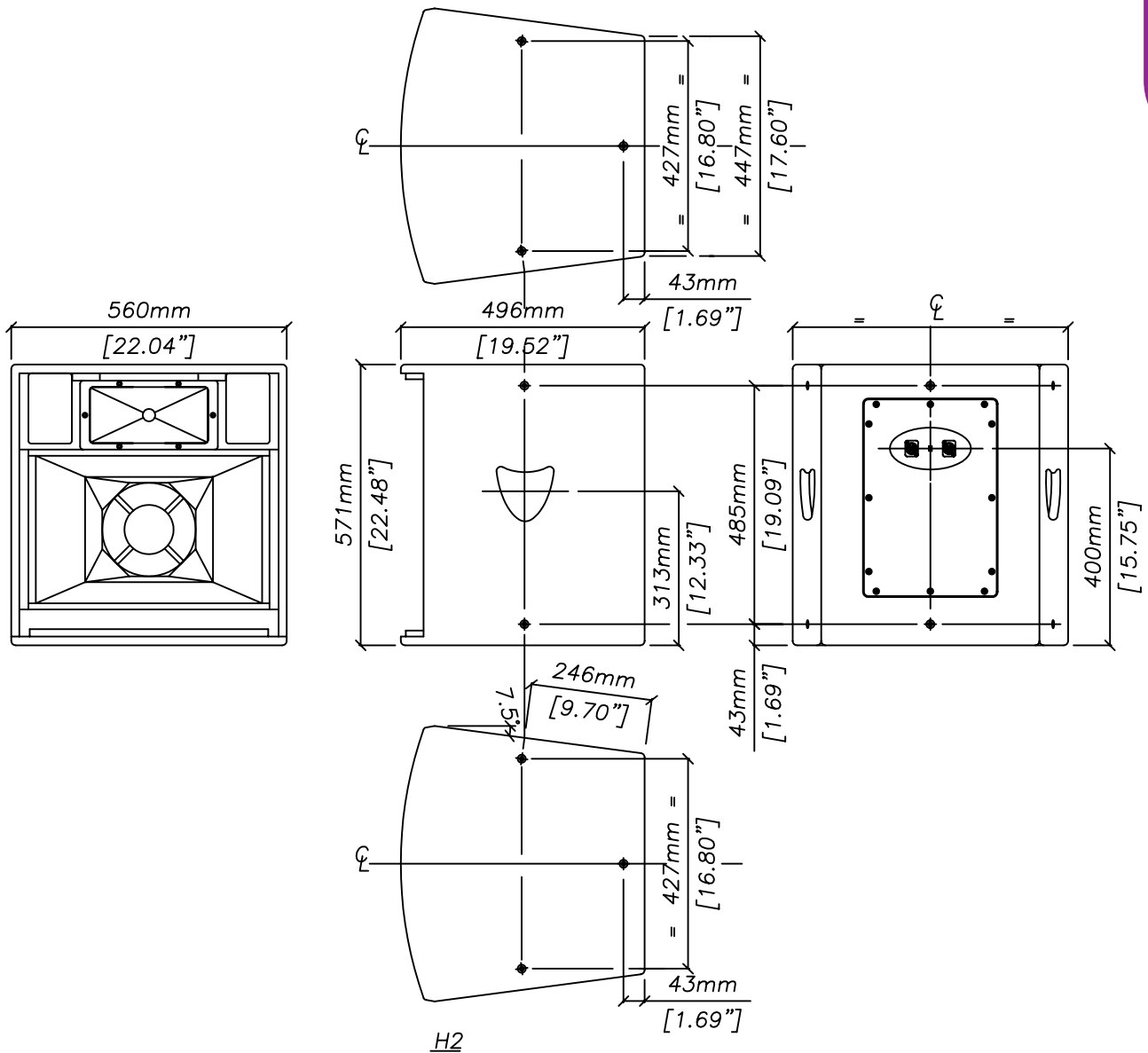

Century Point, Halifax Road, Cressex Business Park,  
High Wycombe, Buckinghamshire HP12 3SL, England.  
Telephone: +44 (0)1494 535312 Facsimile: +44 (0)1494 438669  
E-mail: info@martin-audio.com  
All information is Copyright © 2003 Martin Audio Ltd.



# Blackline H2

Two-way active/passive mid-high

portable club

## technical specifications

TYPE	Two-way active/passive trapezoid Hybrid™ fully horn-loaded
FREQUENCY RESPONSE (1)	150Hz-18kHz ± 3dB
DRIVERS	10" (250mm) mid driver 1" (25mm) exit compression driver
RATED POWER (2)	MF/(MF + HF): 300W AES, 1200W peak HF: 60W AES, 240W peak
RECOMMENDED AMPLIFIER	MF/(MF + HF): 400-650W HF: 100-400W into 4 ohms
SENSITIVITY (3)	MF/(MF + HF): 104dB, HF: 106dB
MAXIMUM SPL (4)	127dB continuous, 133dB peak
NOMINAL IMPEDANCE	MF/(MF + HF): 8 ohms HF: 8 ohms
DISPERSION (-6dB)	70° horizontal, 40° vertical
CROSSOVER	150Hz active, 2kHz passive/active
ENCLOSURE	75 litre, multi-laminate birch ply
FINISH	Textured black paint
PROTECTIVE GRILLE	Black perforated steel
CONNECTORS	2 x Neutrik NL4
FITTINGS	12 x M8 inserts
DIMENSIONS	(W) 560mm x (H) 571mm x (D) 496mm (W) 22ins x (H) 22.5ins x (D) 19.5ins
WEIGHT	35kg (77lbs)

## accessories

HTKCT05	8mm Shouldered Eye Bolt
---------	-------------------------

### Notes

- (1) Measured on-axis in half space at 2 metres, then referred to 1 metre.
- (2) AES Standard ANSI S4.26-1984.
- (3) Measured in half space conditions at 2 metres with 1 watt input, using band limited pink noise, then referred to 1 metre.
- (4) Measured in half space conditions at 2 metres using band limited pink noise, then referred to 1 metre.

### Trade Descriptions Act

Due to Martin Audio's policy of continuing improvement, we reserve the right to alter these specifications without prior notice. Martin Audio is committed to refining state of the art sound reinforcement, combining in-depth product and field applications research with advanced manufacturing techniques. Every Martin Audio product is built to the highest manufacturing standards and rigorously tested to ensure that it meets the performance criteria specified in the design.

## architectural and engineering specifications

The loudspeaker system shall be of the trapezoidal two-way, active/passive, Hybrid™ fully horn-loaded type, consisting of one 10" (250mm) horn and reflex loaded mid frequency transducer with a 'phase-ball' loading device and one 1" (25mm) exit HF compression driver mounted on a constant directivity horn. The enclosure shall be of a multi-laminate birch ply construction with threaded inserts for wall and ceiling mounting. The mid and high frequency sections shall be integrated by a switchable internal 2kHz crossover network to permit either passive or bi-amp operation.

Performance of the loudspeaker system with its electronic controller shall meet or exceed the following criteria:

Frequency response measured 1 metre on axis shall be 150Hz-18kHz ± 3dB.

High frequency dispersion at -6dB points shall be 70° H x 40° V.

Power handling shall be 300W AES, 1200W peak MF/(MF + HF), 60W AES, 240 peak HF.

Rated impedance shall be 8 ohms MF/(MF + HF), 8 ohms HF.

Maximum SPL measured at 1 metre on axis shall be 127dB continuous, 133dB peak.

Dimensions (W) 560mm x (H) 571mm x (D) 496mm (22ins x 22.5ins x 19.5ins).

Weight 35kg (77lbs).

The loudspeaker system shall be the Martin Audio H2.

Century Point, Halifax Road, Cressex Business Park,  
High Wycombe, Buckinghamshire HP12 3SL, England.  
Telephone: +44 (0)1494 535312 Facsimile: +44 (0)1494 438669  
E-mail: [info@martin-audio.com](mailto:info@martin-audio.com)  
All information is Copyright © 2003 Martin Audio Ltd.

