

Effect 5

Two-way passive surround system

cinema

features

- ▶ Two-way passive design
- ▶ THX™ approved
- ▶ 100° x 60° HF horn
- ▶ Simple to install

applications

- ▶ Powerful surround sound applications
- ▶ For large cinemas



The Effect 5 is a two-way passive cinema surround system, designed to produce the wide dynamic range and extended frequency response characteristics of digital sound formats. It is suitable for both medium and large scale cinema applications.

The system features a 10" (250mm) bass driver and a 1" (25mm) exit compression driver mounted on a 100° x 60° horn with constant coverage directivity pattern. The crossover network has been designed to allow easy selection between flat response and the SMPTE/ISO 2969 X-curve.

The shape of the Effect 5 allows it to be wall mounted with a 15° downwards angle by means of its simple fixing bracket. With a high sensitivity of 95dB and wide coverage pattern, it can cover a wide seating area even with high wall placement.

Century Point, Halifax Road, Cressex Business Park,
High Wycombe, Buckinghamshire HP12 3SL, England.
Telephone: +44 (0)1494 535312 Facsimile: +44 (0)1494 438669
E-mail: info@martin-audio.com
All information is Copyright © 2003 Martin Audio Ltd.



Effect 5

Two-way passive surround system

overall dimensions

cinema

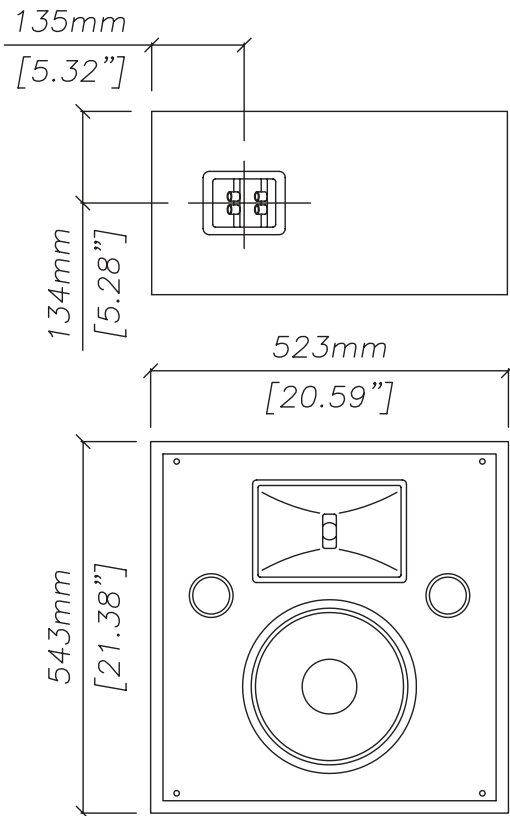

**NOTE:
SHOWN WITHOUT FRONT GRILLE,
DIMENSION WITH GRILLE IS 284mm(11.18")*

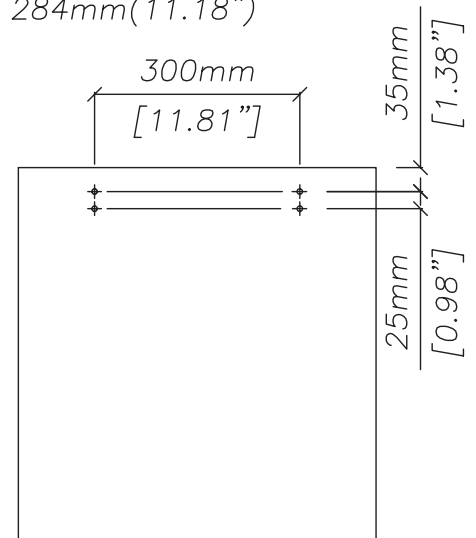
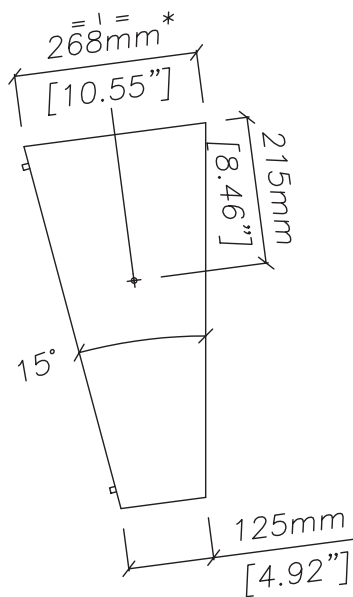

EFFECT 5

Century Point, Halifax Road, Cressex Business Park,
High Wycombe, Buckinghamshire HP12 3SL, England.
Telephone: +44 (0)1494 535312 Facsimile: +44 (0)1494 438669
E-mail: info@martin-audio.com
All information is Copyright © 2003 Martin Audio Ltd.



Effect 5

Two-way passive surround system

technical specifications

TYPE	Two-way passive, reflex enclosure
FREQUENCY RESPONSE (1)	75Hz-20kHz \pm 3dB
LOW FREQUENCY LIMIT	-10dB @ 45Hz
DRIVERS	10" (250mm) bass-mid driver 1" (25mm) exit HF compression driver
RATED POWER (2)	150W AES, 600W peak
RECOMMENDED AMPLIFIER	100-200W into 8 ohms
SENSITIVITY (3)	95dB 1 Watt/1 metre
MAXIMUM SPL (4)	115dB continuous, 121dB peak
IMPEDANCE	8 ohms nominal
DISPERSION (-6dB)	100° horizontal, 60° vertical
CROSSOVER	2kHz passive Externally selectable flat / SMPTE/ISO 2969 X-curve operation
ENCLOSURE	35 litre (1.1 cu foot) particle board construction
FINISH	Black textured vinyl
PROTECTIVE GRILLE	Black acoustically transparent cloth grille
CONNECTORS	2-way binding posts
FITTINGS	4 x M4 teenuts on rear for 'keyhole' brackets 2 x keyhole plates 2 x M8 threaded inserts for wall bracket 1 x wall bracket (optional)
DIMENSIONS	(W) 523mm x (H) 543mm x (D) 287mm (W) 20.6ins x (H) 21.4ins x (D) 11.3ins
WEIGHT	16.5kg (36lbs)

accessories

HTK-EFFECT 5B Adjustable Bracket



approved by Lucasfilm for use in THX™ theatres.

Notes

- (1) Measured on-axis in half space at 2 metres, then referred to 1 metre.
- (2) AES Standard ANSI S4.26-1984.
- (3) Measured in half space conditions at 2 metres with 1 watt input, using band limited pink noise, then referred to 1 metre.
- (4) Measured in half space conditions at 2 metres using band limited pink noise, then referred to 1 metre.

Trade Descriptions Act

Due to Martin Audio's policy of continuing improvement, we reserve the right to alter these specifications without prior notice. Martin Audio is committed to refining state of the art sound reinforcement, combining in-depth product and field applications research with advanced manufacturing techniques. Every Martin Audio product is built to the highest manufacturing standards and rigorously tested to ensure that it meets the performance criteria specified in the design.

architectural and engineering specifications

The loudspeaker system shall be of the two-way passive type consisting of one 10" (250mm) direct radiating reflex loaded low/mid frequency transducer and one 1" (25mm) exit HF compression driver mounted on a constant directivity horn in a slimline enclosure. The enclosure shall be fitted with threaded inserts for mounting brackets. Low and high frequency sections shall be integrated by an internal 2kHz passive crossover network, which is fitted with an external switch to facilitate easy selection between a flat or SMPTE/ISO 2969 X-curve.

Performance of the loudspeaker system shall meet or exceed the following criteria:

Frequency response measured 1 metre on axis shall be 75Hz-20kHz \pm 3dB.

High frequency dispersion at -6dB points shall be 100° H x 60° V.

Power handling shall be 150W AES, 600W peak.

Rated impedance shall be 8 ohms.

Maximum SPL measured at 1 metre on axis shall be 115dB continuous, 121dB peak.

Dimensions (W) 523mm x (H) 543mm x (D) 274mm (20.6ins x 21.4ins x 11.3ins).

Weight 16.5kg (36lbs).

The loudspeaker system shall be approved by Lucasfilm for use in THX™ Theatres.

The loudspeaker system shall be the Martin Audio Effect 5.

Century Point, Halifax Road, Cressex Business Park,
High Wycombe, Buckinghamshire HP12 3SL, England.
Telephone: +44 (0)1494 535312 Facsimile: +44 (0)1494 438669
E-mail: info@martin-audio.com
All information is Copyright © 2003 Martin Audio Ltd.

