

CONTENTS (ENGLISH)		Page No
1	INTRODUCTION	2
2	UNPACKING	3
3	MAINS CONNECTION	3
4	CONNECTIONS	4
4.1	Input Connections	4
4.2	Output Connections	5
5	INITIAL SETTINGS	6
6	WX3A SYSTEM CONFIGURATIONS WITH PLUG-IN BOARDS	6
6.1	WX3A / W2 - Active W2 Configuration (Stereo)	7
6.2	WX3A / W3 - W3 Configuration (Stereo)	7
6.3	WX3A - Sub Bass and Full Range / High Pass Configuration (Stereo)	8
6.4	W1, W2, W3 Passive Operation Using WX3ASF Card (Stereo)	9
6.5	W1, W2, W3 Passive with Sub Bass Operation Using WX3ASF (Stereo)	9
6.6	Mono Sub Bass	10
6.7	Active W2/W3 with Sub Bass Operation Using WX3AW2LF Card or WX3AW3LF Card (Stereo)	10
6.8	WX3A W2 Mono With Sub Bass Configuration	12
6.9	WX3A W3 Mono With Sub Bass Configuration	12
7	LEVELS	13
8	LIMITERS	13
9	WARRANTY	14
10	TECHNICAL SPECIFICATIONS	15



The Martin Experience



Standards Applied

EMC Emission	EN55103-1:1996
Immunity	EN55103-2:1996
Electrical Safety	EN60065:1998

This equipment conforms to the requirements of the EMC Directive 89/336/EEC, amended by 92/31/EEC and 93/68/EEC and the requirements of the Low Voltage Directive 73/23/EEC, amended by 93/68/EEC.

1 INTRODUCTION

Thank you for purchasing a Martin Audio WX3A System Controller. The WX3A is used to optimise the performance of Wavefront Series loudspeakers.

Crossover functions, relative output levels and phase adjustments are all preset for a given Wavefront system by means of a dedicated system-specific plug-in board.

A user adjustable low-distortion limiter is fitted to each band.

Each band features output level adjustment, from -ve infinity to +6dB relative to its nominal level. All inputs and outputs are electronically balanced. This feature in conjunction with extremely low system noise makes the WX3A ideal for theatre and other critical applications.

2 UNPACKING

Each Martin Audio WX3A controller is built to the highest standard and thoroughly inspected before it leaves the factory. After unpacking the unit, examine it carefully for any signs of transit damage and inform your dealer if any such damage is found. It is suggested that you retain the original packaging so that the unit can be repacked at a future date if necessary.

Please note that Martin Audio and its distributors cannot accept responsibility for damage to any returned product through the use of non-approved packaging.

3 MAINS CONNECTION

The WX3A is provided with an IEC 320 type mains receptacle. It is supplied with a 2m mains lead terminated with a standard IEC 320 plug, which must be connected as below:

GREEN/YELLOW	-	EARTH
BROWN	-	LIVE
BLUE	-	NEUTRAL

Mains voltage tolerance $\pm 10\%$ on each setting.

Fuses type T semi delay 100-120V 500mA(L), 220-240V 250mA(L)

WARNING: The WX3A controller must always be operated with the mains safety earth connected.

To change the mains voltage, remove the rectangular fuse cap and replace it so that the arrow on the body of the rectangle indicates the correct voltage. The earth terminal on the IEC connector is permanently connected to the metal casing. The unit is supplied with the 0V electronic reference ground taken to the case via an internal 'signal ground' lead and space receptacle, which inserts a ground lift resistor when in the 'Earth Off' position. To connect the 0V electronic reference direct to the chassis ground, use a pair of pliers to pull off the space receptacle from the 'Earth Off' position and push it onto the 0V spade terminal (marked Earth On, on the PCB).

This equipment must be earthed.



**CAUTION
RISK OF ELECTRIC SHOCK
DO NOT OPEN
DO NOT EXPOSE TO RAIN
OR MOISTURE**

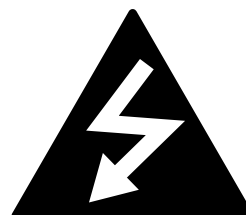

It should not be necessary to remove any protective earth or signal cable shield connections.

4 CONNECTIONS

4.1 Input Connections

WX3A inputs are on female XLR type connectors and are electronically balanced. Pin 1 is normally open circuit but may be linked to sig 0V or chassis earth by inserting a link on the PCB (see Fig 1). The signal is always applied between Pin 2 (hot +) and Pin 3 (cold -).

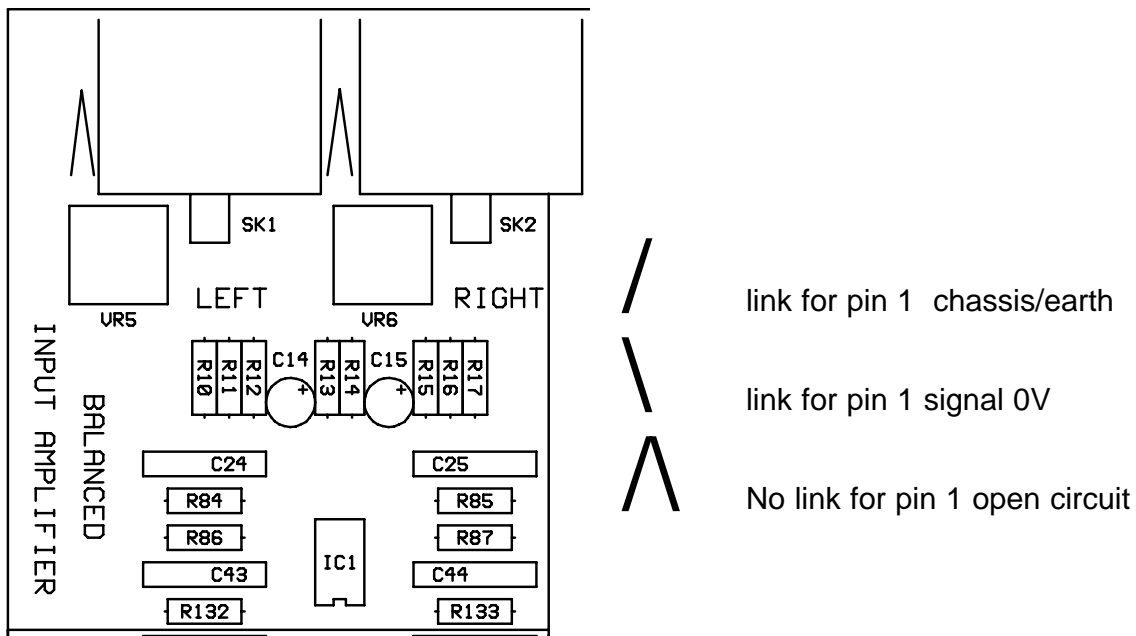

Fig. 1

Always use 2-core + screen 'balanced' type signal leads, even for unbalanced circuits. The screen should be regarded as separate from the signal return, even if they are connected together at one end of the line.

For either balanced or unbalanced operation, always connect the signal between Pins 2 and 3. The input cable shield should be derived from equipment which is sourcing the input provided that normal safety requirements are met (ie the mains earth is correctly connected). See Fig 2.

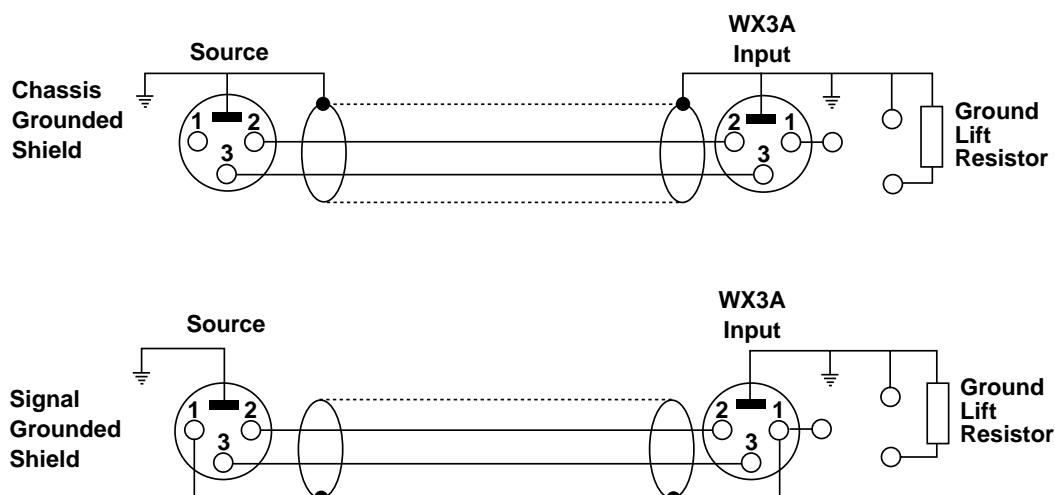

Fig. 2

4.2 Output Connections

The WX3A outputs are electronically balanced auto compensating via male XLR type connectors. Pin 1 is the (ground) connection and the signal appears between Pins 2 and 3.

Always use 2-core + screen 'balanced' type signal leads, even for unbalanced circuits. The screen should be regarded as separate from the signal return, even if they are connected together at one end of the line. This is to keep the screen a true screen so that no signal return currents flow through it which can induce signals in adjacent cables.

For unbalanced use, having decided which pin is 'hot', connect the 'cold' pin and (Pin 1) together. The internal signal ground lead should be placed in the earth off position at the WX3A outputs which allows the amplifier to be locally grounded (as required for safety reasons) without causing a hum loop. If the signal is merely taken between either Pin 2 or 3 and Pin 1, a level loss and signal degradation will occur.

For balanced operation, the screen should be connected to ground at the amplifier end. To eliminate ground current loops, it can be lifted at the WX3A output, provided normal safety requirements have been met (i.e. the mains earths are correctly connected). See Fig 3.

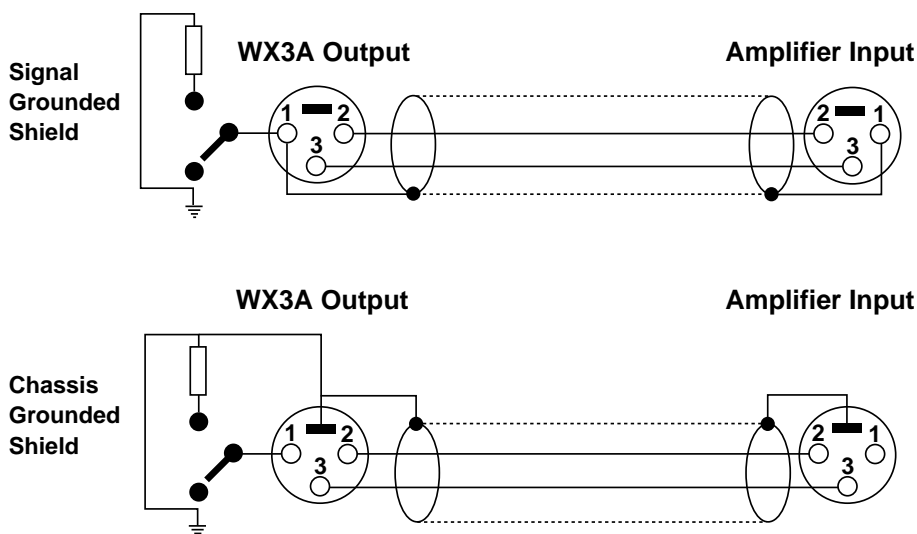

Fig. 3

5 INITIAL SETTINGS

WX3A units are supplied with the adjustments set as follows:

Mains Voltage	-	240V
Ground Switch	-	ON
Limiter Threshold	-	2V setting
Plug-in Board	-	System specific

6 WX3A SYSTEM CONFIGURATIONS WITH PLUG-IN BOARDS

The WX3A used in conjunction with a plug-in board becomes a dedicated system controller. Depending on the plug-in system-specific board, the WX3A is automatically configured either as a stereo 2-way or mono 3-way device for a specific Wavefront system.

Each plug-in board dictates a system-specific crossover function, equalisation and in some cases group delay.

Mounted on each plug-in board are jumper links. The links determine various low frequency equalisation (LF EQ) options. They are set by the user according to the application of the system. The various options concerning LF EQ are outlined in the following. These should be examined carefully, especially when using sub-bass in a system.

6.1 WX3A / W2 - Active W2 Configuration (Stereo)

The WX3AW2LF board is used to control the W2 when operated as an active 2-way system (see Fig 4). Active crossover frequency (1500Hz), relative output levels, driver alignment and equalisation are all pre-set for the W2 system. LF EQ circuitry gives 6dB of boost at 65Hz for full-range operation.

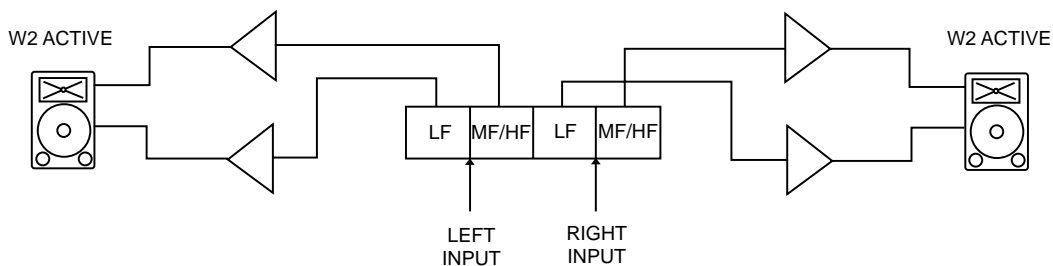

Fig 4. W2 Active Configuration using WX3AW2LF Card.

6.2 WX3A / W3 - W3 Configuration (Stereo)

The WX3AW3LF board is used to control the W3 loudspeaker system (see Fig 5). Active crossover frequency (650Hz), relative output levels, driver alignment and equalisation are all pre-set for the W3 system. LF EQ circuitry gives 6dB of boost at 65Hz for full-range operation.

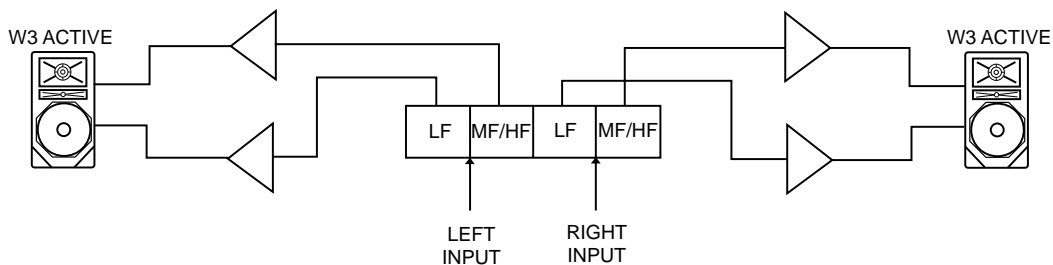

Fig 5. W3 Active Configuration using WX3AW3LF Card.

6.3 WX3A - Sub Bass and Full Range/High Pass Configuration (Stereo)

The WX3ASF plug-in board is used to control the W1, passive W2 and passive W3 when operating either as stand-alone full-range systems or with additional WS2 sub-bass enclosures.

It is also used to provide the outputs for other WX3A controllers configured to drive active W2 and W3 systems used in stereo with WS2 sub-bass enclosures.

PCB mounted jumper links on the plug-in board select various alignment options for the full-range/high pass outputs (Bands 2 and 4). See Fig 6.

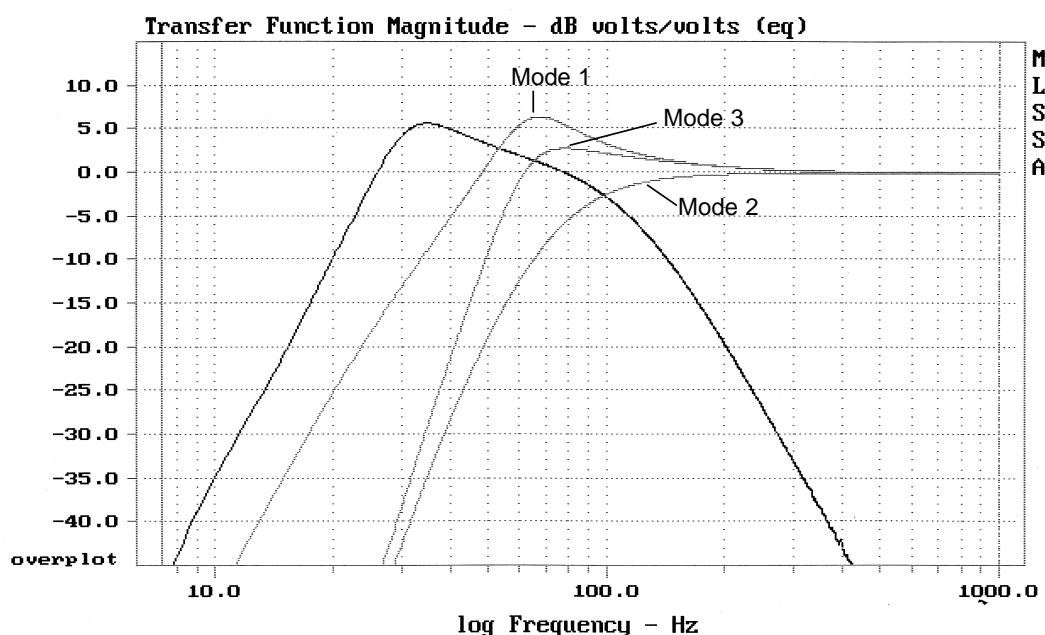

Fig. 6

If full-range mode (1) is selected, +6dB of low frequency boost at 65Hz is applied to the full-range outputs (Bands 2 & 4).

If 100Hz high-pass crossover mode (2) is selected, the full-range outputs are re-configured as 100Hz high-pass outputs.

In Overlap Mode (3), the sub-bass and full-range enclosures are allowed to overlap and 3dB of LF boost is applied to the full-range enclosure. This can be useful when the full-range systems are flown some distance from the sub-bass. This mode allows some low frequency energy to be reproduced by the flown loudspeakers without using up as much headroom as would be required if the full-range +6dB low frequency boost were applied.

Plug-in board jumper link positions are as follows:

	Jumper	Position	Jumper	Position
Mode (1), Full Range	J4/J5	B	J1/J7	OUT
	J3/J6	A	J2/J8	OUT
Mode (2), 100Hz high-pass	J4/J5	A	J1/J7	IN
	J3/J6	B	J2/J8	IN
Mode (3), Overlap	J4/J5	B	J1/J7	IN
	J3/J6	A	J2/J8	IN

6.4 W1, W2, W3 Passive Operation Using WX3ASF Card (Stereo)

A WX3A controller is used to provide LF equalisation and limiter functions for stand-alone W1, W2 and passive W3 systems operated full-range (see Fig 7). In this instance the W1, W2 and W3 should be driven from Bands 2 and 4 set to operate in full-range Mode (1) (see Section 6.3).

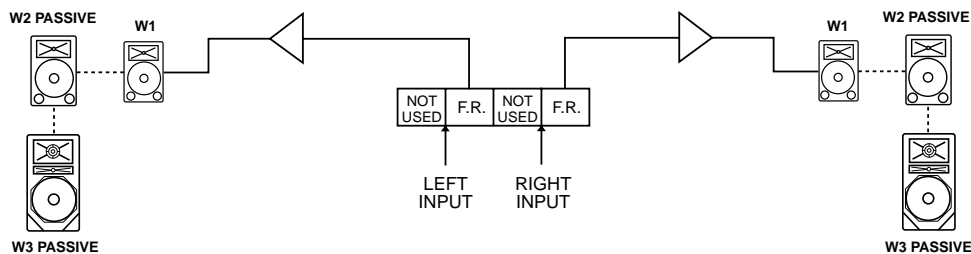

Fig 7. W1, W2 or W3 Passive operation using WX3ASF Card

6.5 W1, W2, W3 Passive with Sub Bass Operation Using WX3ASF (Stereo)

The WX3ASF may also be used to drive a sub-bass system to augment the W1, W2 and passive W3 systems (see Fig 8). The WX3A is normally operated in 100Hz high-pass/crossover Mode (2) (see Section 6.3) for this configuration, although it may be operated in Overlap Mode (3) if overlap is required for flown systems. Full-range Mode (1) should only be used with care, in special cases where distant flown systems are required to run full-range. Some cancellation may occur if the W1, W2 and W3 are located in close proximity to the sub-bass enclosure. However, this cancellation may simply be resolved by reversing the phase of the W1, W2 or W3.

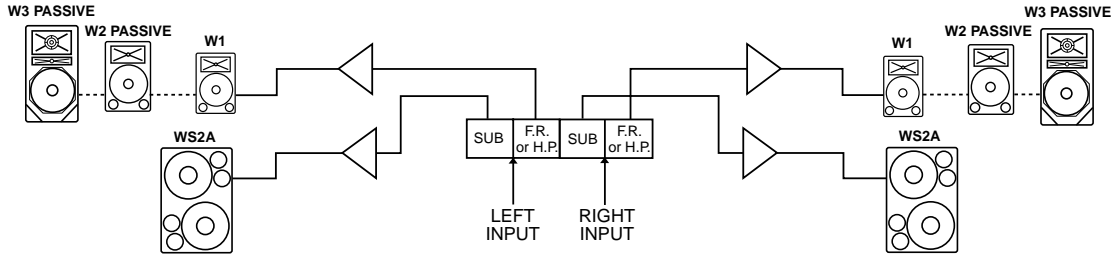

Fig 8. W1, W2 or W3 Passive operation with Sub Bass using WX3ASF Card

6.6 Mono Sub Bass

J9 on the WX3ASF Card can be used to mono sum channels 1 and 3.

6.7 Active W2/W3 with Sub Bass Operation Using WX3AW2LF Card or WX3AW3LF Card (Stereo)

An additional controller fitted with a WX3ASF card may be used to drive a sub-bass system to augment stereo W2 and W3 systems and their controllers (see Fig 9).

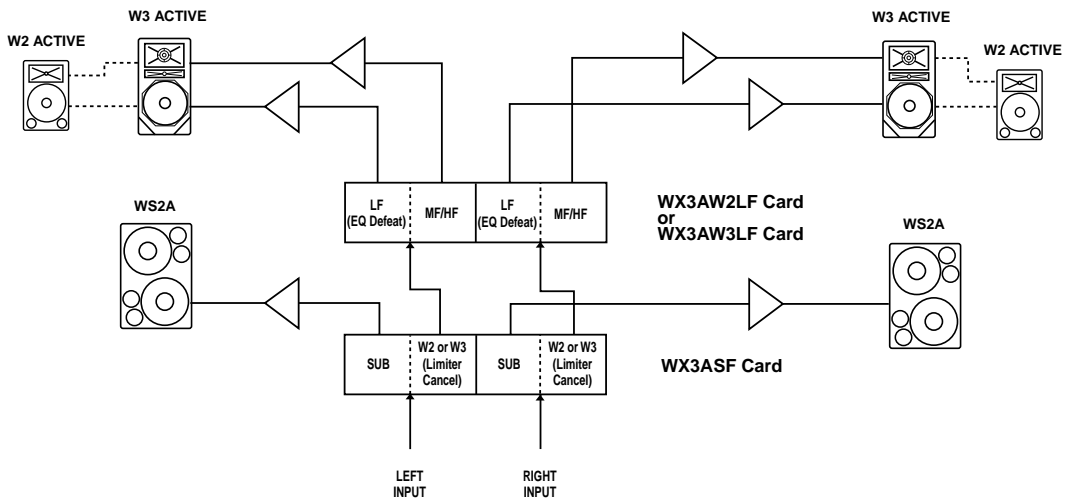
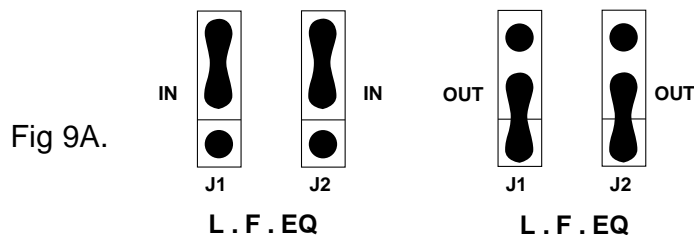

Fig 9. Normal operation for augmenting Stereo W2/W3 Active with Sub Bass

In this set-up, the LF EQ of the WX3AW2LF or WX3AW3LF cards on Bands 1 & 3 should be switched out. This is achieved by moving jumper links J1 – J2 on the card from the IN position to the OUT position (see Fig 9A)



The limiters on the high-pass outputs of the WX3A driving the W2's or W3's should also be defeated to prevent them operating in advance of following units. To defeat the limiters on Bands 2 & 4, move jumper links J2 and J4 on the main circuit board to the left position. Please refer to Section on limiters for further information.

The WX3ASF is normally operated in 100Hz high-pass/crossover mode (2) (see Section 6.3) for this configuration, although it may be operated in overlap mode (3) if overlap is required for flown systems.

Full-range mode (1) should only be used with care, in special cases where distant flown systems are required to run full-range. Some cancellation may occur if the W3/W2 are used in close proximity to the sub-bass enclosure. However, this cancellation may be resolved by simply reversing the phase of the W2 or W3.

For special effects applications, instead of the normal method of feeding the high-pass outputs of the WX3ASF controller to a WX3A controller (as shown in Fig 10), the WX3ASF controller may be connected in parallel as an effects bandpass filter. The input to the sub-bass controller can either be connected to the main left/right signal (parallel inputs) or may be fed from a separate input signal. The W2 and W3 are left to run full-range (see Sections 6.1/6.2).

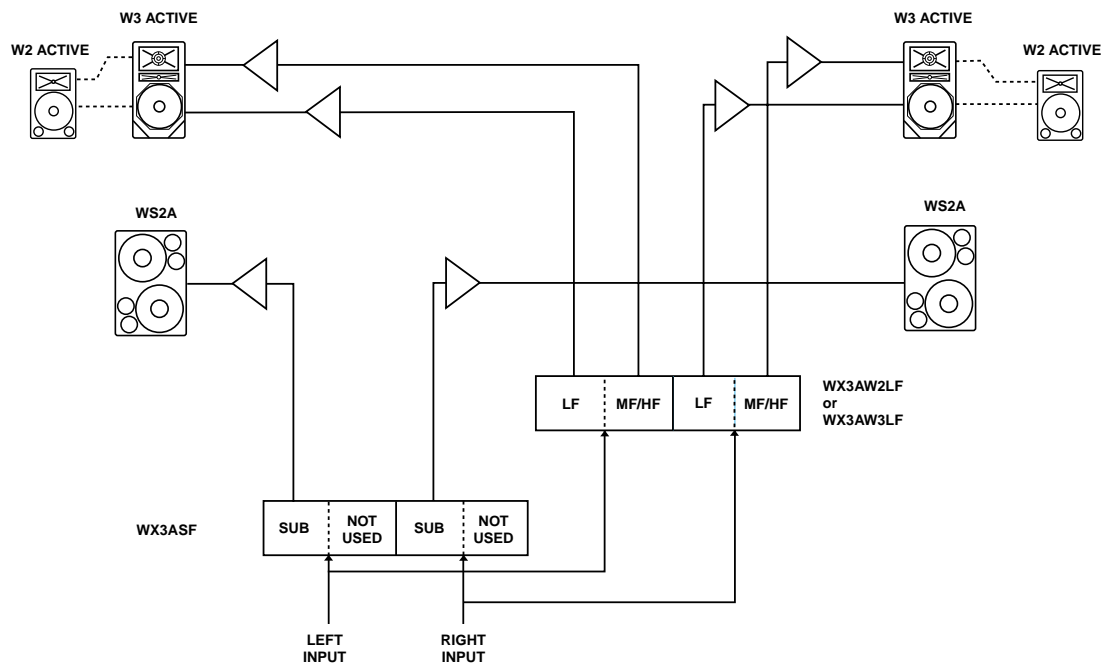

Fig 10. Parallel operation for augmenting Stereo W2/W3 Active with Sub Bass

In this parallel configuration it should be noted that, because the effect of LF EQ circuit in the WX3/W2 (or W3) is still present in the full-range output, some LF cancellation might occur. This may be especially noticeable if the full-range systems are used in close proximity to the sub-bass enclosures. LF cancellation due to this effect may simply be resolved by reversing the phase of the W2 or W3.

6.8 WX3A W2 Mono With Sub Bass Configuration

The W2 Active + Sub mono configuration is used to control a single channel active W2 system when used with a sub-bass (see Fig 11). Active crossover frequencies (100Hz, 1500Hz), relative output levels, driver alignment and equalisation are all pre-set for the W2 system plus sub-bass.

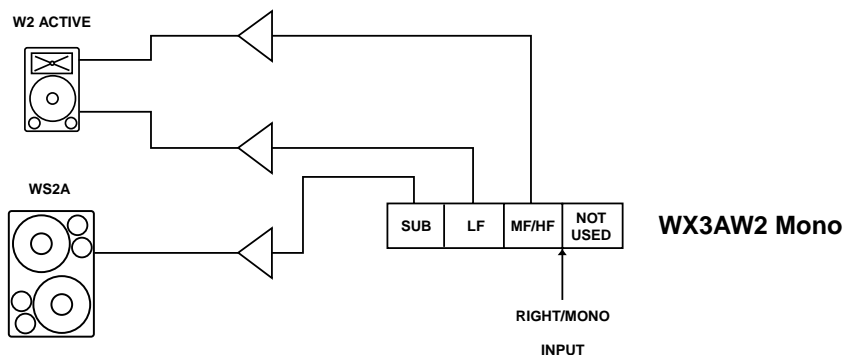

Fig 11. W2 Active + Sub configuration using WX3AW2 mono card

6.9 WX3A W3 Mono With Sub Bass Configuration

The W3 Active + Sub mono configuration is used to control a single channel active W3 system when used with a sub-bass (see Fig 12). Active crossover frequencies (100Hz, 650Hz), relative output levels, driver alignment and equalisation are all pre-set for the W3 system plus sub-bass.

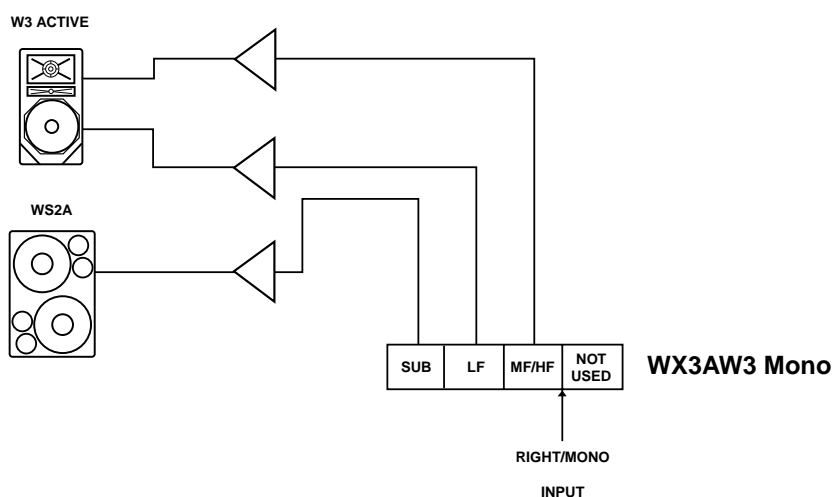

Fig 12. W3 Active + Sub configuration using WX3AW3 mono card

7 LEVELS

Each output level may be adjusted from -ve infinity to +6dB relative to its nominal level. The system-specific plug-in boards include mid and high frequency band attenuation to provide level matching for approximate system balance when all controls are set to 0dB (assuming the use of amplifiers with identical gains). It should be noted, therefore, that front panel calibration would not necessarily indicate absolute band gains within the WX3A. When setting up a system for the first time, the WX3A band levels should be adjusted for desired balance and the settings noted for future reference.

8 LIMITERS

The WX3A system controller features fast attack limiters to prevent power amplifiers from clipping, thus providing speaker protection whilst preserving full system headroom. The limiters are set by adjusting the limit threshold switches to the value that matches the input sensitivity of the amplifier. A system operated in this way, with amplifiers having a power rating as recommended for the particular Wavefront system and used by experienced professional sound engineers, should be sufficiently protected from overdriving. Amplifier gain controls should normally be set at maximum. Triggering of the limiter is indicated by a red LED on the front panel.

Recommended amplifier powers for Wavefront Series loudspeakers are as follows:

W1	300-400 watts per channel into 4 ohms
W2/W3	400-600 watts per channel into 4 ohms
W3P	550-800 watts per channel into 4 ohms
WS2A	550-800 watts per channel into 4 ohms

Limiter threshold settings may be altered by removing the top panel of the WX3A case (two screws each side) to gain access to the main circuit board.

The limiter threshold is set by a 16-way switch on each band. This is located on the main circuit board behind each corresponding band level control. The switches are labelled as follows:

BAND 1	S 1
BAND 2	S 2
BAND 3	S 3
BAND 4	S 4

Threshold values corresponding to the switch settings are printed on the main circuit board for easy reference when making adjustments.

They are:

0	1	2	3	4	5	6	7	8	9	A	B	C	D	E	F
0.2	0.4	0.5	0.7	0.9	1.1	1.3	1.4	1.6	1.8	2.0	2.2	2.3	2.5	2.7	2.9

If operated by inexperienced personnel or in situations where abuse is likely, limiter switches can be backed off 2 or 3 positions to lower 'safe' thresholds. This will ensure that the output of the amplifiers cannot exceed the long-term continuous power ratings of the drive units.

Each limiter may be defeated if required by moving jumper links J1-J4 on the main circuit board to the left position.

	<u>JUMPER</u>	<u>POSITION</u>	<u>LIMITER</u>
BAND 1	J1	RIGHT	ON
		LEFT	OFF
BAND 2	J2	RIGHT	ON
		LEFT	OFF
BAND 3	J3	RIGHT	ON
		LEFT	OFF
BAND 4	J4	RIGHT	ON
		LEFT	OFF

IMPORTANT NOTE

If another WX3A is to be driven from any of the outputs - for instance when a WX3ASF provides the high-pass outputs for a WX3A configured for an active W2 or W3 - the limiters should be defeated on those outputs to prevent them from operating in advance of the limiters in the following units (see Fig 9).

9 WARRANTY

Martin Audio WX3A System Controllers are warranted against manufacturing defects in materials or craftsmanship over a period of 1 year from the date of original purchase. During the warranty period Martin Audio will, at its discretion, either repair or replace products which prove to be defective provided that the product is returned in its original packaging, shipping prepaid, to an authorised Martin Audio service agent or distributor.

Martin Audio Ltd. cannot be held responsible for defects caused by unauthorised modifications, improper use, negligence, exposure to inclement weather conditions, act of God or accident, or any use of this product that is not in accordance with the instructions provided by Martin Audio. Martin Audio is not liable for consequential damages.

This warranty is exclusive and no other warranty is expressed or implied. This warranty does not affect your statutory rights.

10 TECHNICAL SPECIFICATIONS

WX3A

INPUTS	2 Electronically Balanced
IMPEDANCE	36K ohms (18K ohms per leg single ended)
CMRR	67dB 20-10KHz
CONNECTORS	3 Pin female XLR
OUTPUTS	4 Electronically Balanced
SOURCE IMPEDANCE	47 ohms
MIN LOAD IMPEDANCE	500 ohms
MAX OUTPUT	+20dBu into 500 ohms limiter defeated
CONNECTORS	3 Pin Male XLR
FREQUENCY RESPONSE	-3dB @ 25 Hz 12dB / octave -3dB @ 35KHz 12 dB / octave (ultimately set by system parameters)
DISTORTION+NOISE	0.009% THD @ 2V output (limiters cancelled)
SIGNAL+NOISE/ NOISE RATIO	>97dB's @ 2V output 20Hz – 20KHz quasi peak o/c input
LIMITERS	Individual for each channel. With program related attack times. Ratio 20:1. Threshold range -12dBu to +12dbu, in 16 steps
INDICATORS	2-way stereo, 3/4 way-mono LED's. Signal present, threshold and LED's on each band
PROTECTION	Auto muting relays and soft start (4 seconds)
MAINS SUPPLY	IEC mains connector with integral fuse holder
MAINS VOLTAGE	Externally selectable on IEC inlet 100-120-220- 240V AC, 50/60Hz. Voltage tolerance on each setting $\pm 10\%$
MAINS FUSE	220-240V: -250mA Type 'T'(L) 100-120V: -500mA Type 'T'(L)
DIMENSIONS	(W) 482mm x (H) 44mm x (D) 211mm (W) 19ins x (H) 1.75ins x (D) 8.3ins
WEIGHT	3.5kg (7.7lbs)
SHIPPING DIMENSIONS	(W) 530mm x (H) 120mm x (D) 310mm (W) 21ins x (H) 4.7ins x (D) 12.2ins
SHIPPING WEIGHT	4.1kg (9lbs)

Due to our policy of continuous improvement all specifications are subject to change without notice

WX3A System Controller



Please Click here to
return to main menu



Please Click here to
visit our website



The Martin Experience

Century Point, Halifax Road, Cressex Business Park, High Wycombe, Buckinghamshire HP12 3SL, England.
Telephone: +44 (0)1494 535312 Facsimile: +44 (0)1494 438669
Web: www.martin-audio.com E-mail: info@martin-audio.com

WX3A System Controller

User's Guide



ENGLISH



The Martin Experience