

<b>CONTENTS (ENGLISH)</b>		<b>Page No</b>
1	INTRODUCTION	2
2	UNPACKING	2
3	AMPLIFICATION	3
4	CONNECTING TO AN AMPLIFIER	3
5	SYSTEM CONFIGURATIONS	3
6	WARRANTY	5
7	TECHNICAL SPECIFICATIONS	6



**The Martin Experience**



Standards Applied

EMC Emission	EN55103-1:1996
Immunity	EN55103-2:1996
Electrical Safety	EN60065:1993

This equipment conforms to the requirements of the EMC Directive 89/336/EEC, amended by 92/31/EEC and 93/68/EEC and the requirements of the Low Voltage Directive 73/23/EEC, amended by 93/68/EEC.

## 1 INTRODUCTION

Thank you for purchasing a Martin Audio EM120 loudspeaker system. The EM120 is a sub-bass system designed to be used in conjunction with compact full-range loudspeakers such as the EM15 and EM26 in situations where extended low frequency output is required.

Ideally suited to background and foreground music reproduction, the EM120 is ultra-compact and easily installed. An external crossover is not necessary, but an EMX1A controller will increase the versatility of the complete system, adding relative level control and driver protection.

The EM120 features a single, long excursion 10" (250mm) bass driver with a 2.5" (65mm) voice coil.

## 2 UNPACKING

Each Martin Audio loudspeaker is built to the highest standard and thoroughly inspected before it leaves the factory. After unpacking the system, examine it carefully for any signs of transit damage and inform your dealer if any such damage is found. It is suggested that you retain the original packaging so that the system can be repacked at a future date if necessary. Please note that Martin Audio and its distributors cannot be held responsible for damage to any returned product through the use of non-approved packaging.

### 3 AMPLIFICATION

---

The EM120 is designed to be used with a professional power amplifier capable of producing 400-500W into 4 ohms:

Care should be taken to avoid amplifier clipping. It is important to understand that a low power amplifier driven into clipping is more likely to damage a loudspeaker than a higher power amplifier used within its ratings. This is because music signals have a high peak-to-average "crest" factor. When an amplifier is severely overdriven, its output waveform is clipped (its peaks are squared off) – reducing the crest factor. In extreme cases, the waveform can approach that of a square wave. An amplifier is normally capable of producing far more power under these conditions than its undistorted rated power output.

The use of very high power amplifiers with outputs greater than those recommended is discouraged.

Care should be taken to avoid switch-on surges, which can result in momentary power peaks in excess of specified ratings. When powering up a sound system it is important to switch on the amplifiers after the mixer and control electronics have stabilised. When powering down the system, reverse the sequence and switch off the amplifiers first.

### 4 CONNECTING TO AN AMPLIFIER

---

Connections are made via stripped wires to avoid the need for soldered connectors. The EM120 enclosure is provided with a pair of 4mm screw terminals.

The impedance of the EM120 is 8 ohms.

Note: It is important to maintain consistent polarity throughout i.e. Red to Red, Black to Black.

### 5 SYSTEM CONFIGURATIONS

---

The basic system configuration for one EM120 and up to three EM15's is shown in Fig 1. Up to three EM15's (each in 16 ohm configuration) are wired in parallel with the input of the EM120, and driven from one channel of the power amplifier. This arrangement presents a 3 ohm load to the amplifier. Alternatively, one EM120 may be used with a single EM26, presenting a 4 ohm load to the amplifier.

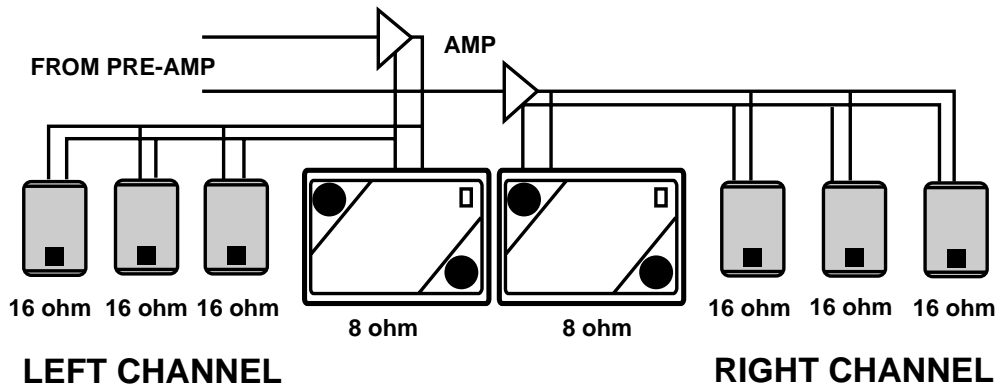

(Fig 1)

To allow for the addition of further EM15's and balance control between the EM15's and the EM120, a further power amplifier channel may be added to the system as shown in Fig 2. The same signal is fed into both amplifiers, one driving the EM15's, the other driving the EM120.

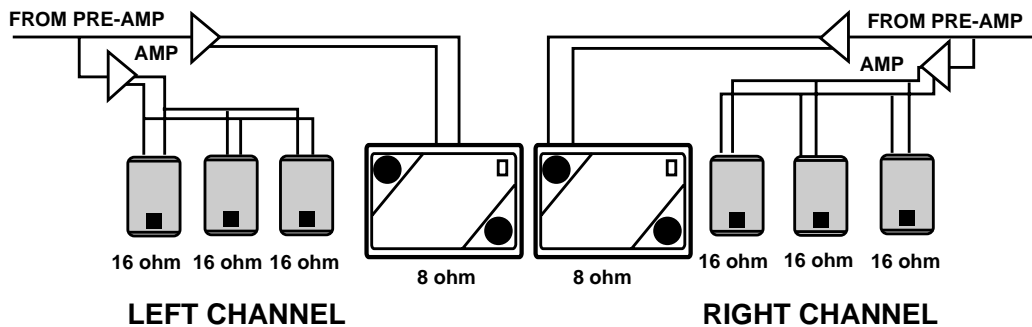

(Fig 2)

An EMX1A controller may be used to further increase the flexibility of the system (see Fig 3). With an EMX1A controller the relative levels can be balanced in the controller. The EMX1A also provides signal limiting for driver protection and has a 120Hz electronic crossover, removing signals below this point from the EM15's.

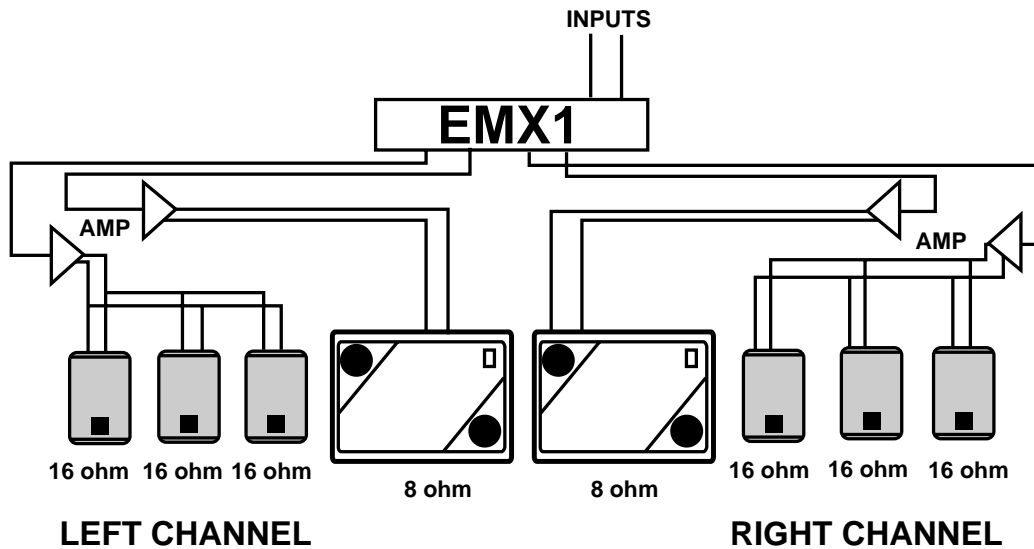

(Fig 3)

Note: Care must be taken, when connecting EM15's in parallel, to ensure that the total load impedance presented to the power amplifier will not exceed the minimum specified by the amplifier manufacturer.

## 6 WARRANTY

Martin Audio EM120 loudspeakers are warranted against manufacturing defects in materials or craftsmanship over a period of 5 years from the date of original purchase. During the warranty period Martin Audio will, at its discretion, either repair or replace products which prove to be defective provided that the product is returned in its original packaging, shipping prepaid, to an authorised Martin Audio service agent or distributor.

Martin Audio Ltd. cannot be held responsible for defects caused by unauthorised modifications, improper use, negligence, exposure to inclement weather conditions, act of God or accident, or any use of this product that is not in accordance with the instructions provided by Martin Audio. Martin Audio is not liable for consequential damages.

This warranty is exclusive and no other warranty is expressed or implied. This warranty does not affect your statutory rights.

## 7 TECHNICAL SPECIFICATIONS

### EM120

TYPE	Ultra compact sub-bass system
FREQUENCY RESPONSE (1)	50Hz-180Hz $\pm$ 3db
RATED POWER (2)	200W AES, 800W peak
SENSITIVITY (3)	95dB 1Watt/1 metre
MAXIMUM SPL (4)	120dB continuous, 126dB peak
RECOMMENDED AMPLIFIER	400-500W (into 4 ohms)
NOMINAL IMPEDANCE	8 ohms
BASS	1 x (10") 250mm extended throw
ENCLOSURE	50 litres (1.56 cu foot), vented
CONNECTOR	1 x pair of binding posts
DIMENSIONS	(W) 450mm x (H) 360mm x (D) 410mm (W) 17.7ins x (H) 14.2ins x (D) 16.1ins
WEIGHT	17.5kg (38 lbs)
SHIPPING DIMENSIONS	(W) 480mm x (H) 390mm x (D) 450mm (W) 18.9ins x (H) 15.4ins x (D) 17.7ins
SHIPPING WEIGHT	19kg (41 lbs)

#### Notes

1. Measured on-axis in half space at 2 metres, then referred to 1 metre.
2. AES Standard ANSI S4.26-1984.
3. Measured in half space conditions at 2 metres with 1 watt input, using band limited pink noise, then referred to 1 metre.
4. Measured in half space conditions at 2 metres using band limited pink noise, then referred to 1 metre.

Due to our policy of continuous improvement all specifications are subject to change without notice.

# EM Series EM120

 Please Click here to  
return to main menu

 Please Click here to  
visit our website



**The Martin Experience**

Century Point, Halifax Road, Cressex Business Park, High Wycombe, Buckinghamshire HP12 3SL, England.  
Telephone: +44 (0)1494 535312 Facsimile: +44 (0)1494 438669  
Web: [www.martin-audio.com](http://www.martin-audio.com) E-mail: [info@martin-audio.com](mailto:info@martin-audio.com)

# EM Series EM120

## User's Guide

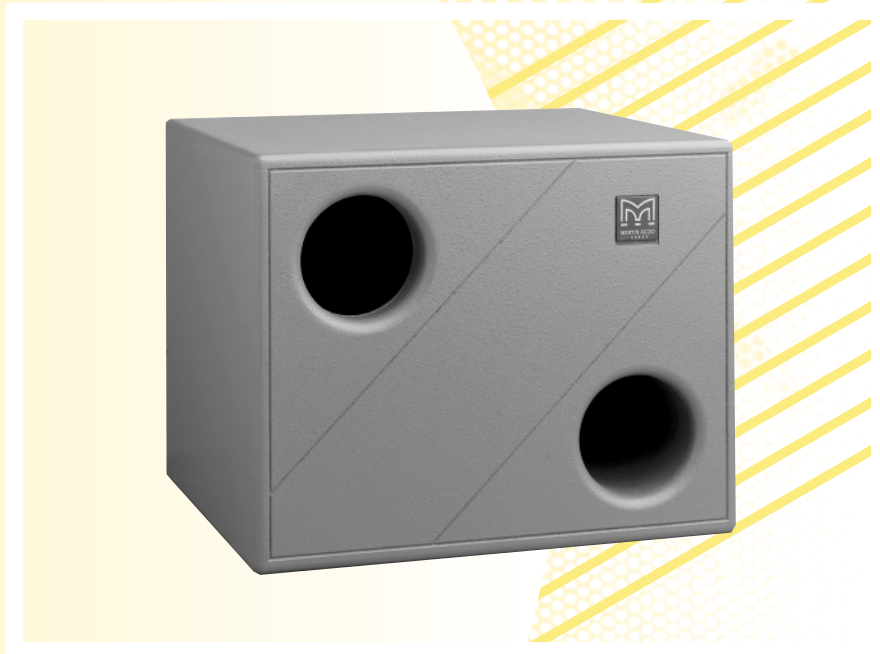

**ENGLISH**



**The Martin Experience**